

18 Pull releasing wire out of locking cylinder. Turn cap to the left (max. 1 turn) until detent of locking cylinder engages in groove of cap.

19 Check locking cylinder for function.

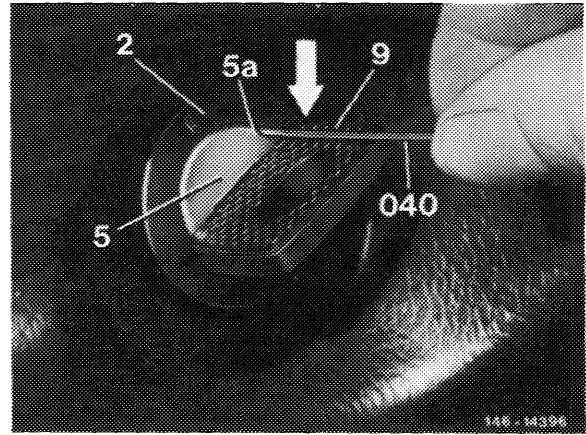

20 On both steering lock versions, insert collar into instrument panel.

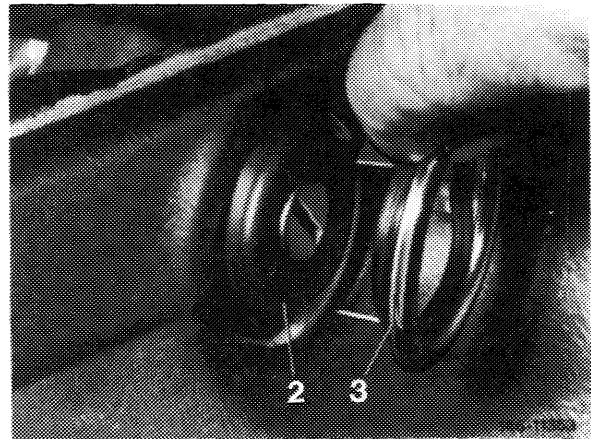

C. Complete removal and installation of steering lock

Note: If locking cylinder is defective and cannot be turned to position "1", the locking pin cannot be pushed in completely. For removing steering lock and after releasing lower steering shaft from upper steering shaft, we recommend removing complete jacket tube, so that the locking pin can be drilled out.

Removal

- 1 Remove cover at left under instrument panel.
- 2 Remove instrument cluster while pulling out instrument cluster as far as possible.
- 3 Loosen tachometer shaft, both electrical plug connections and oil pressure line.

4 Remove plug connection (15) on starter switch of steering lock.

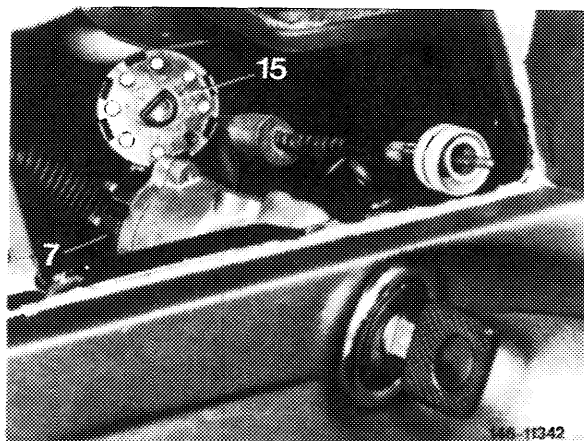

5 On diesel vehicles with steering lock starter switch, pull both vacuum lines (14) and (15) from connecting hoses of vacuum valve.

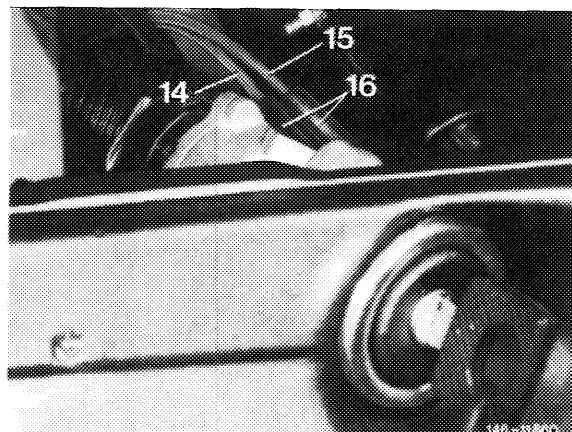

6 On diesel vehicles without steering lock starter switch, loosen cable control (arrow) to pre-glow starter switch on steering lock.

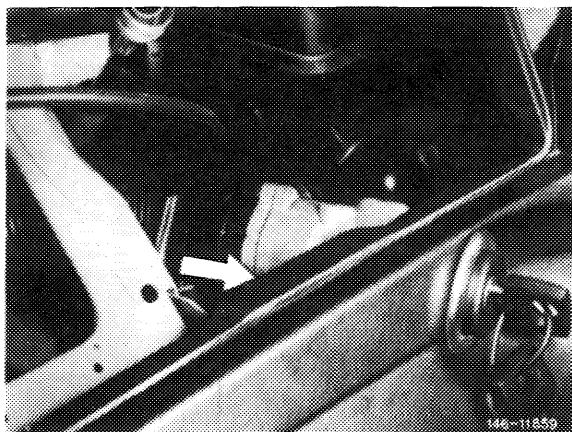

7 Remove collar (3) from instrument panel by bending holding plates upwards.

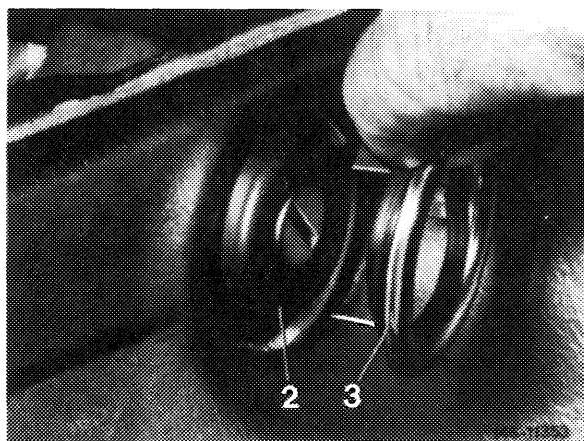

Steering lock 1st version (plug-type cap made of plastics)

8 Pull off key and pull cap from steering lock by means of a steel wire 1 mm thick, which is offset at end by approx. 1.5 mm.

Note: The cap must be removed to turn steering lock during subsequent removal.

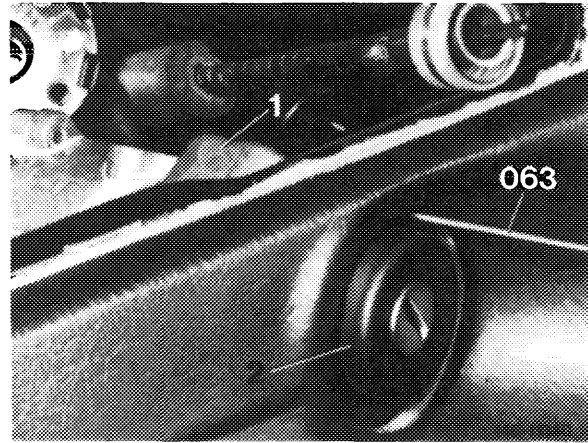

Steering lock 2nd version (screw-type cap)

9 Turn locking cylinder into position "1" with ignition key.

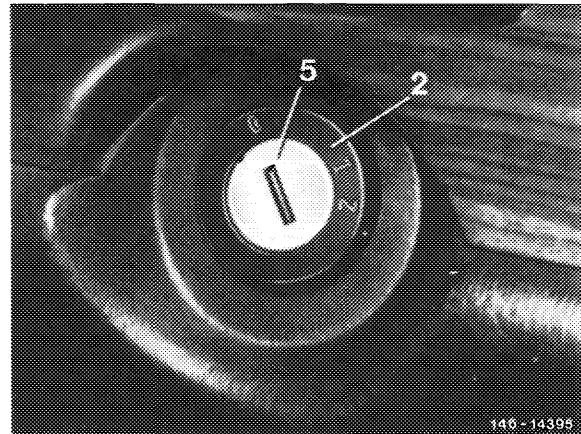

10 Introduce releasing wire (040) through bore (5a) in locking cylinder. Then push down releasing wire and unlock detent of locking cylinder by overcoming resilient resistance.

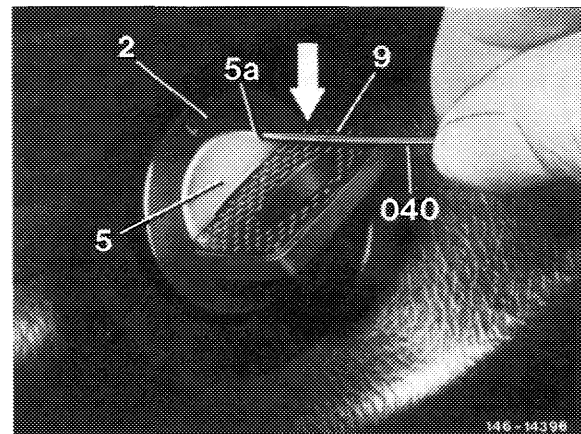

Note: The releasing wire is self-made from steel wire 1.25 mm thick according to adjacent drawing.

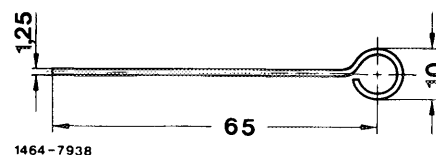

11 Unscrew cap from steering lock with detent disengaged.

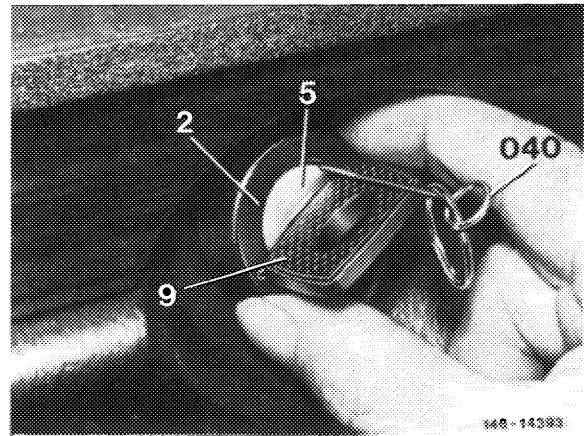

12 Remove cap including locking cylinder from steering lock. Pull releasing wire out of locking cylinder. Turn ignition key to position "0" and pull out.

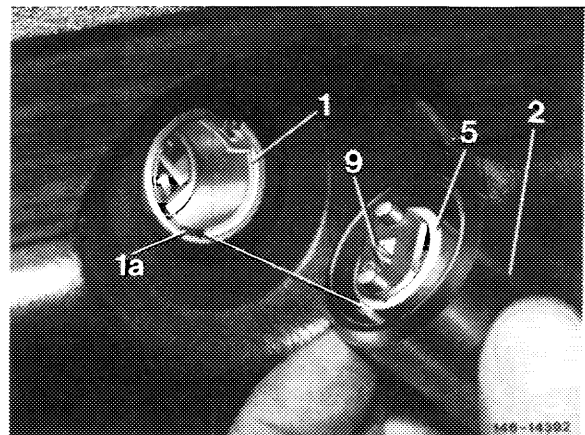

13 Remove locking cylinder from cap.

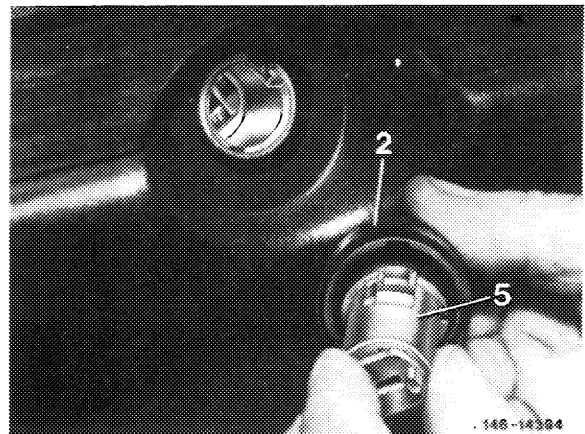

14 Turn locking cylinder into position "1", push-down detent (6) and insert locking cylinder without cap into steering lock.

15 Remove both covers at left from under instrument panel.

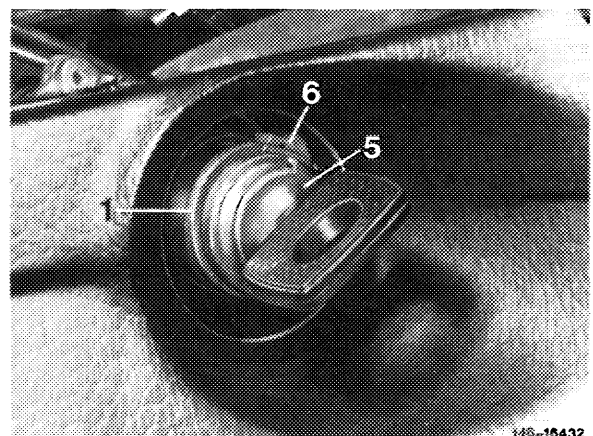

16 Pull plug connection from contact switch (8).

17 On both versions, loosen clamping screw of fastening clamp (15).

18 Reinsert key and turn to position "1", the so-called assembly or radio position.

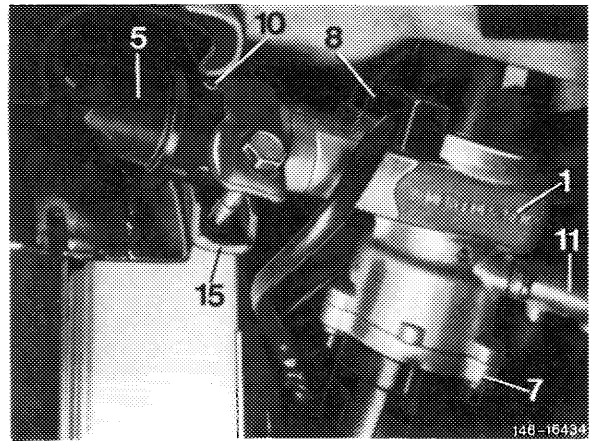

19 Push-in locking pin (10) for steering lock (6) with a punch approx. 3 mm thick (refer to arrow). Slightly turn steering lock. Turn ignition key into position "0" and pull out. Remove steering lock from holder (5) of jacket tube and instrument panel.

Attention!

The locking pin can be pushed-in only in position "1" of steering lock. The pin represents an additional burglar lock.

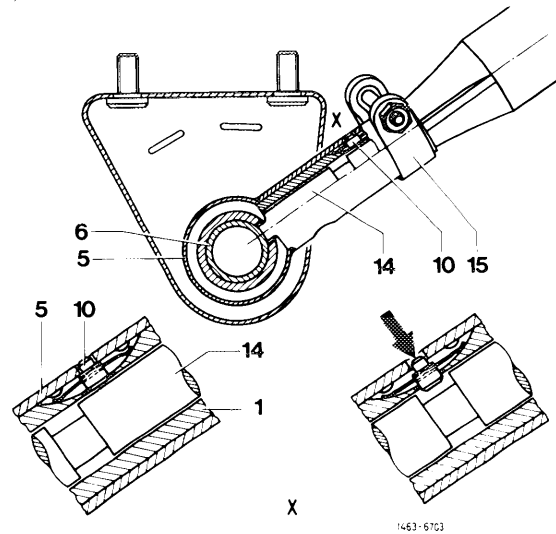

20 Turn locking cylinder into position "1" and remove contact switch (8) from steering lock.

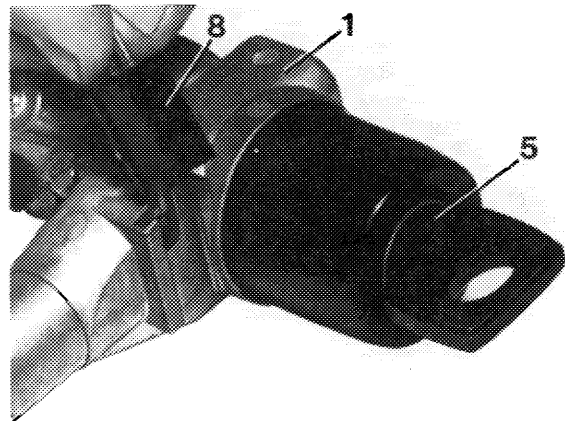

21 With steering lock 2nd version in position "1", push-in detent (6) and remove locking cylinder (5) from steering lock.

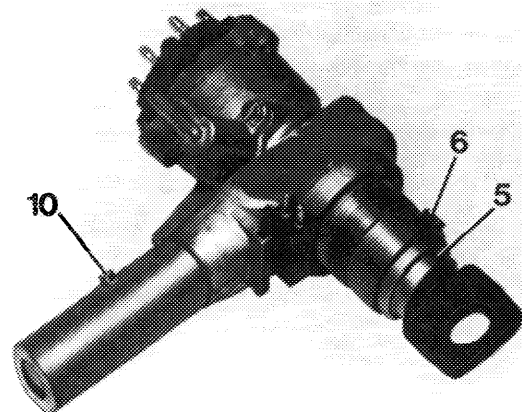

Installation

Note: On vehicles with gasoline engines, as well as on vehicles with diesel engines **with steering lock starter switch**, only the steering lock 3rd version (with screw-type cap) is available as a spare part after steering locks of 1st and 2nd version have been used up.

If instead of a steering lock of 1st or 2nd version a steering lock of the 3rd version is installed, the cutout in instrument panel for cap must be made larger by cutting some material from panelling. In addition, install a collar with a larger diameter.

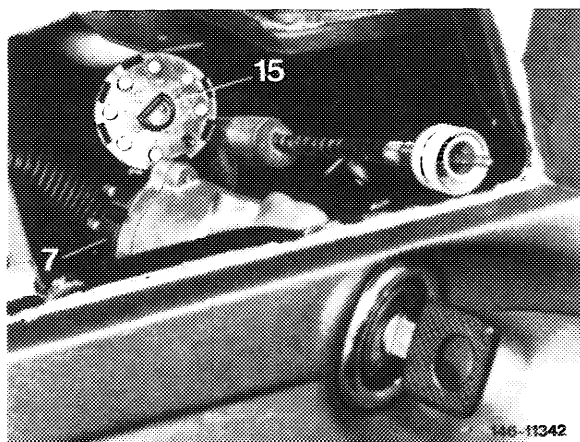

Steering lock 1st version (plug-type cap made of plastics)

22 Insert contact switch into steering lock and turn locking cylinder into position "1". Push-in locking pin, turn key into position "0" and pull out, while keeping locking bolt of steering lock in position.

23 Insert steering lock into holder of jacket tube. Make sure that the locking pin (10) engages in bore of holder.

24 Push cap into correct position on steering lock. Pay attention to recesses on cap.

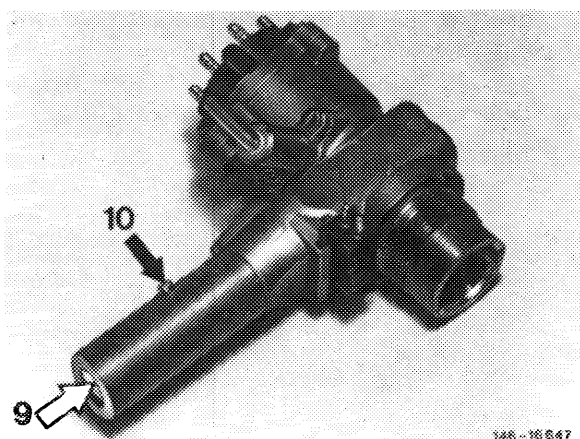

Steering lock 2nd version (screw-type cap)

25 Insert contact switch into steering lock. Push closing pin (9) into steering lock until locking pin (10) is no longer blocked.

26 Push locking pin into steering lock and insert steering lock into holder of jacket tube.

27 Turn steering lock until locking pin (10) engages in bore of holder.

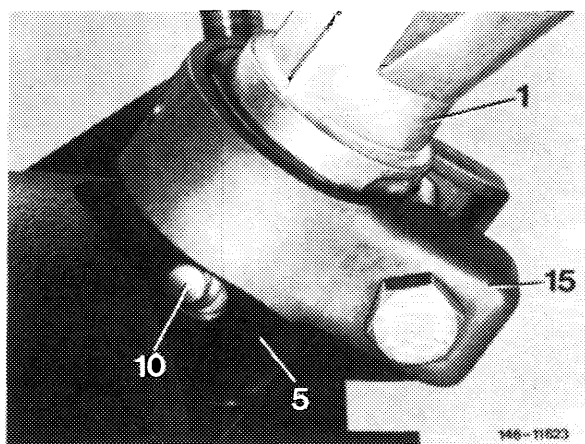
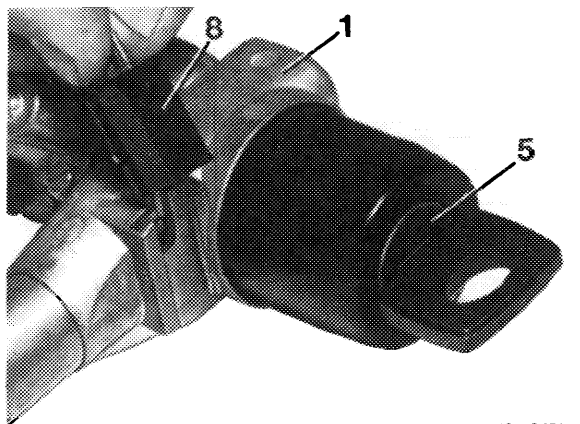

28 Insert locking cylinder into cap in such a manner that detent (6) enters groove of cap (arrow).

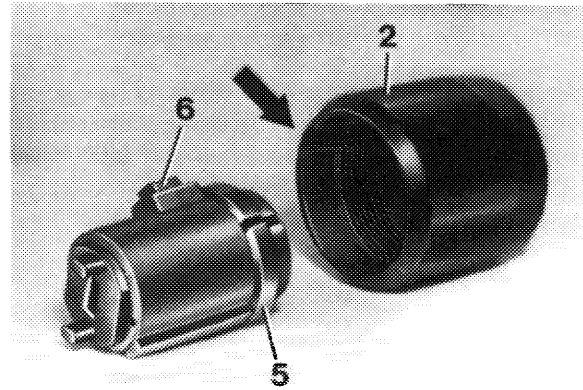

146 - 14390

29 Insert ignition key into locking cylinder and turn to position "1".

30 Unlock detent by means of release wire (040) through bore (5a) in locking cylinder.

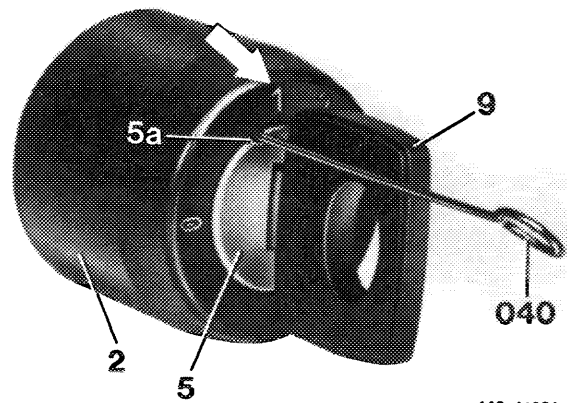

146 - 14391

31 Lightly coat threads in cap or threads of steering lock with Anticorit PRC II or anti-friction bearing grease.

32 Position cap including locking cylinder at steering lock in such a manner that the raised portion on locking cylinder enters groove of steering lock (arrow).

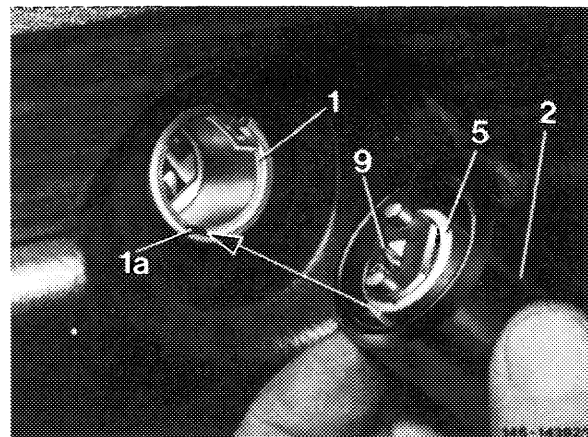

33 Screw cap completely on steering lock.

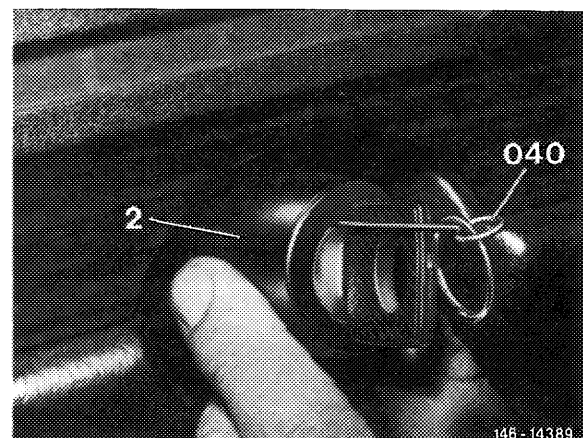

146 - 14389

34 Pull releasing wire from locking cylinder. Turn cap to the left (max. 1 turn) until detent of locking cylinder engages in groove of cap.

35 Check locking cylinder for function.

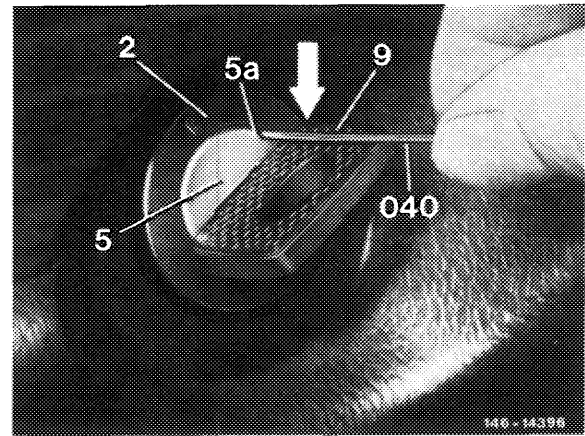

36 On both versions, insert collar into instrument panel.

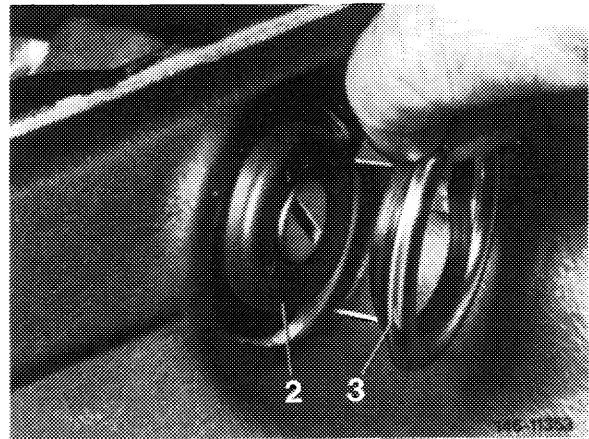

37 Tighten clamping screw of fastening clamp (15).

38 Mount plug connection on contact switch (8).

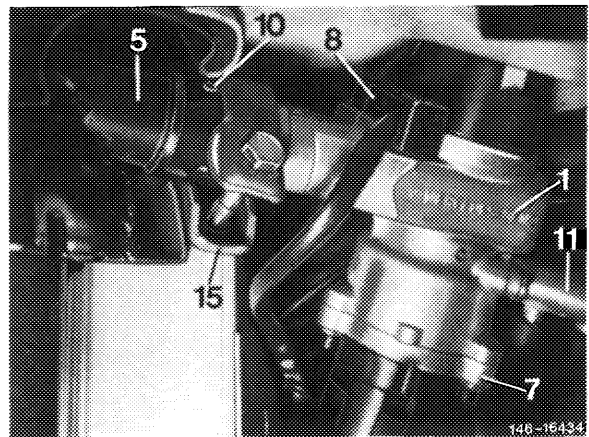

39 On diesel vehicles **with** steering lock starter switch, connect vacuum line (14) and (15) to valve of steering lock.

Note: The brown line (15) comes from vacuum pump and is connected to upper connection. The brown/blue line (14) leads to vacuum control unit of injection pump and is connected to lower connection (to steering lock).

Minimum insertion depth of lines into connection (16) 12 mm. Make sure that the connections are inserted up to stop of vacuum valve.

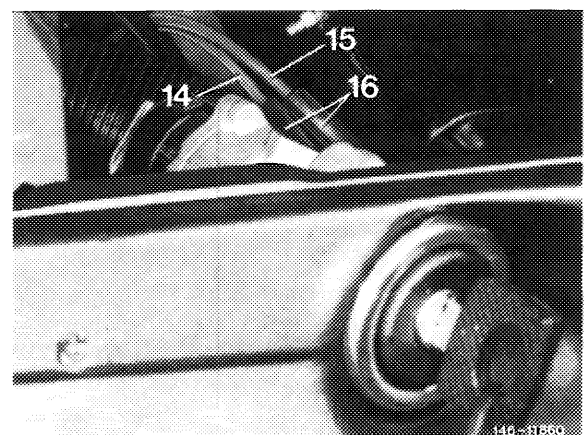

40 On diesel vehicles **without** steering lock starter switch, attach cable control for preglow starter switch to steering lock, while paying attention to dimension "a", which should amount to 22.7 ± 0.5 mm. If required, set to correct dimension by adjusting knurled screw on pre-glow starter switch. Reference dimension "b" = 165 mm.

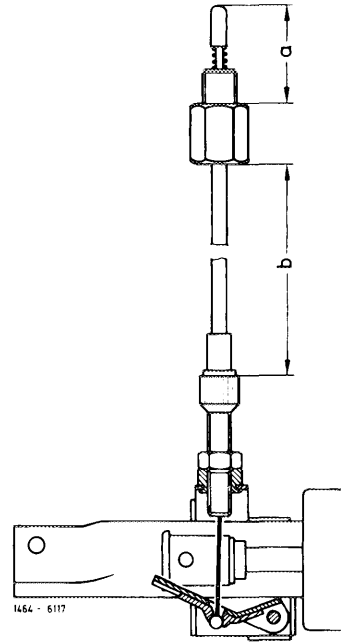

- 41 Insert collar into instrument panel and bend holding plates.
- 42 Install instrument cluster and connect both electrical plug connections, the oil pressure line and the tachometer shaft.
- 43 Check function of steering lock.
- 44 Install cover.

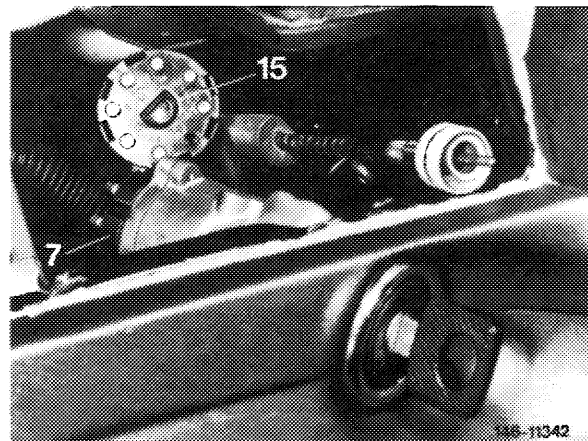

D. Removal and installation of vacuum valve

Removal

- 1 Remove instrument cluster and pull out cluster as far as possible, disconnect tachometer shaft, both electric plug connections and oil pressure line.
- 2 Loosen both vacuum lines (14) and (15) from vacuum valve.
- 3 Completely remove steering lock (section C).
- 4 Screw both slotted screws out of steering lock and remove vacuum valve.

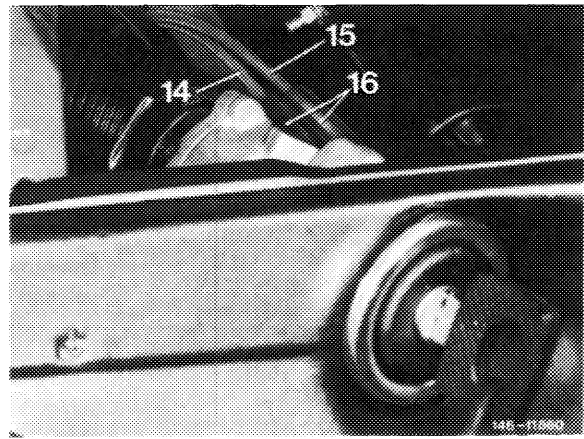

Installation

- 5 Attach vacuum valve (11) to steering lock.
- 6 Slip both connections on to connecting pipes of valve up to stop.
- 7 Install steering lock (46-640, section C).
- 8 Connect both vacuum lines to connections.

Note: The brown line (15) comes from vacuum pump and is connected to upper connection "A", the brown/blue line (14) leads to vacuum control unit of injection pump and is connected to lower connection "B".

Minimum insertion depth of lines into connections (16) 12 mm. Make sure that the connections are inserted up to stop of vacuum valve.

9 Install instrument cluster and connect both electrical plug connections, oil pressure line and tachometer shaft.

10 Check vacuum line for function by starting and stopping engine several times.

